



# SMART Board® QX (V2) Pro series with iQ



## Display

<b>Screen sizes (diagonal)</b>	65"   75"   86"
<b>Backlight</b>	LED
<b>Aspect ratio</b>	16:9
<b>Maximum display resolution</b>	4K UHD (3840 × 2160)
<b>Refresh rate</b>	60 Hz
<b>Lifespan</b>	≥ 50,000 hours
<b>Brightness<sup>1</sup></b>	490 cd/m <sup>2</sup>
<b>Display response time</b>	≤ 8 ms
<b>Viewing angle</b>	178°
<b>Glass</b>	Optically bonded   Anti-glare   Anti-fingerprint   Heat-tempered
<b>Frame color</b>	Black
<b>Convenience buttons</b>	Power   Home   Volume   Microphone mute   Freeze frame
<b>Sensors</b>	Proximity   Ambient light   Infrared   Room temperature   Humidity   Volatile organic compound (VOC)   Particulate Matter (PM <sub>2.5</sub> ) <sup>2</sup>
<b>Audio</b>	Integrated soundbar featuring two 20 W speakers and a 15 W subwoofer  Integrated linear eight-microphone array with visual mute status indicator and support for onboard acoustic echo cancellation
<b>Video</b>	4K, 8.28MP, ePTZ with 10× Digital Zoom, 120FOV See > <a href="#">SMART Ultra HD Camera 120</a>

<b>NFC</b>	Integrated RFID NFC reader/writer CCID (chip card interface device) when used with a native operating system driver for Windows®, Linux®, or Mac  Supported protocols: ISO 14443A/B, ISO 15693, NFC Tag 1-4
------------	--

## Interactive experience

<b>Touch technology</b>	HyPr Touch™ with Advanced IR
<b>Touch features</b>	Simultaneous tool differentiation Object Awareness™ Pen ID™ SilkTouch™ Pressure sensitive ink Palm rejection Tool Explorer™ v2
<b>Typical touch response time</b>	≤ 4 ms
<b>Frame rate</b>	≥ 300 Hz
<b>Accuracy</b>	1 mm
<b>Minimum object size</b>	2 mm
<b>Multitouch capabilities</b>	Up to 50 touch points (OS dependent)
<b>Tools included</b>	Stylus with multi-color select and fine eraser (×2) Erasers with angle of orientation (×2)
<b>Tool holders</b>	Intelligent   Magnetic   Frame-mounted

<sup>1</sup>Brightness of individual displays can vary.

<sup>2</sup>The display's environmental sensors are not life safety rated sensors: they provide general information only.

Software	
<b>Included</b>	iQ embedded Android™ OS SMART Meeting Pro® <ul style="list-style-type: none"> <li>Room license</li> <li>Personal licenses (×10)</li> </ul> SMART Product Drivers and SMART Ink® SMART Remote Management <sup>3</sup>
<b>Optional</b>	SMART TeamWorks™

iQ embedded Android OS	
<b>Operating system</b>	Android version 13.0 Supports an automatic update to Android 15
<b>CPU</b>	Octa-core
<b>Memory</b>	8 GB DDR4
<b>OS architecture</b>	64-bit
<b>Storage</b>	64 GB (up to 576 GB)
<b>User interface</b>	4K UHD (3840 × 2160)
<b>Digital whiteboard</b>	✓
<b>Web browser</b>	✓
<b>Screen sharing</b>	✓
<b>Google Play™ Protect Certified<sup>4</sup></b>	✓
<b>Google Play Store</b>	✓
<b>Other features</b>	Personalized home screen and settings Split screen Templates, graphic organizers, and manipulatives File and app libraries Environmental sensors dashboard Tool Explorer™ Image Editor
<b>Ability to run third-party applications</b>	✓
<b>Cloud storage access</b>	✓
<b>NFC sign in to a SMART Account</b>	✓
<b>Device-based sign in to a SMART Account</b>	✓

<sup>3</sup>Subscription for the length of the included warranty

<sup>4</sup>Pending final testing

Languages supported	Basque   Catalan/Valencian   Chinese (simplified)   Chinese (traditional)   Czech   Danish   Dutch   English   Estonian   Finnish   French   Galician   German   Greek   Hungarian   Italian   Japanese   Korean   Latvian   Lithuanian   Norwegian   Polish   Portuguese   Romanian   Russian   Slovak   Slovenian   Spanish   Swedish   Ukrainian   Vietnamese   Welsh
Updates	Automatic over-the-air (OTA)

PC computing	
<b>OPS support<sup>5</sup></b>	SMART PCM modules
<b>PC module power supported OPS</b>	100 W
<b>Optional computing module</b>	See > <a href="https://smarttech.com/accessories">smarttech.com/accessories</a>

Inputs	Front	Back
OPS PC accessory slot	–	1
MicroSD slot with security cover	–	1
HDMI® 2.1 4K @ 60Hz with HDCP 1.4, HDCP 2.3, ARC, and eARC support <sup>6</sup>	1	3
VGA video	–	1
Stereo 3.5 mm (variable)	–	1
RS-232 (DB-9 connector)	–	1
RJ45 (LAN In)	–	1
USB Type-C 4K @ 60Hz, Display Port 1.2, USB 2.0 (UFP) for touch and digital audio, USB 3.2 Gen 1 (DFP) for peripherals; 65 W power delivery	1	1
USB Type-C, SuperSpeed (5 Gbps); 15 W power delivery	–	1 (top)
USB 2.0 Type-A	–	1
USB 3.2 Gen 1 Type-A	2	2
USB 3.2 Gen 1 Type-B	1	3

<sup>5</sup>The support and performance of third-party OPS (Open Pluggable Specification) and OPS-C modules may vary. Conduct proper compatibility testing to avoid potential issues.

<sup>6</sup>ARC and eARC support are available only with the HDMI 2 input.

Outputs	Front	Back
HDMI 2.1 4K @ 60Hz with HDCP 2.3 support	–	1
USB Type-C 4K @ 60Hz Display Port 1.4a, HDCP 2.3 and HDCP 1.3, USB 3.2 Gen 1 (DFP) for touch ingest and peripherals; 4.5 W power delivery	–	1
Stereo 3.5 mm (variable)	–	1
S/PDIF optical (fixed)	–	1
RJ45 (LAN Out)	–	1

Included cables and accessories	Qty
Country-specific power cable	1
16' 5" (5 m) USB 2.0 A to B cable	1
6' (1.8 m) USB4 Type-C cable, 100W	1
Stylus with multi-color select and fine eraser	2
Bar erasers	2
External dual-band (2.4 and 5 GHz) antennas	2
Remote control	1
AAA batteries	2
SMART Ultra HD Camera with mounting and cable accessories	1
Illustrated installation instructions	1
Important information document	1

### Connectivity

<b>Wired</b>	RJ45 (x2) 1000BASE-T
<b>Wi-Fi</b>	IEEE 802.11ax (Wi-Fi 6e) supporting WPA, WPA2, WPA3 PSK, and 802.1X EAP authentication protocols
<b>Bluetooth</b>	5.2 dual mode

### Storage and operating requirements

<b>Power requirements</b>	100V to 240V AC, 50 Hz to 60 Hz
<b>Operating temperature</b>	41–95°F (5–35°C)
<b>Storage temperature</b>	–4–140°F (–20–60°C)
<b>Humidity</b>	5–80% relative humidity, non-condensing

### Power consumption

<b>Typical</b>	65": 94 W 75": 105 W 86": 122 W
<b>Standby</b>	<0.5 W

### Certification and compliance<sup>7</sup>

<b>Regulatory models</b>	IDQX65-1   IDQX75-1   IDQX86-1
<b>US / Canada</b>	UL   FCC   ISED   TSCA   CONEG Packaging   Proposition 65
<b>EU / EEA / EFTA / UK</b>	CE   UKCA   LVD   CB   EMC   RED   REACH   RoHS   Battery   WEEE   Packaging   POP   Ecodesign
<b>Australia / New Zealand</b>	RCM
<b>Performance standards</b>	ENERGY STAR®   HDMI   HDCP

### Purchasing information<sup>8</sup>

#### Order numbers

<b>QX265-V2-P</b>	SMART Board® QX065-V2 Pro interactive display with iQ
<b>QX275-V2-P</b>	SMART Board QX075-V2 Pro interactive display with iQ
<b>QX286-V2-P</b>	SMART Board QX086-V2 Pro interactive display with iQ

### Optional accessories

<b>WM-SBID-200</b>	SMART Wall Mount for SMART interactive displays
<b>Other accessories</b>	See > <a href="https://smarttech.com/accessories">smarttech.com/accessories</a>

### SMART Warranty

Terms and conditions and warranty upgrade options vary by region. Visit [smarttech.com/warranty](https://smarttech.com/warranty) or contact your reseller for information.

<sup>7</sup>Product availability may vary by region.

This product has received additional certifications not listed here.

<sup>8</sup>Order numbers may vary by region.

### Cable requirements

See > *SMART cables and connectors guide*  
([docs.smarttech.com/kb/171926](https://docs.smarttech.com/kb/171926))



**Installation, dimensions, and weights**

**Notes**

- All dimensions ± 1/8" (0.3 cm). All weights ± 2 lb. (0.9 kg).
- Product ships upright.
- Leave space around the display to ensure adequate ventilation.

**65" models**

**Dimensions**

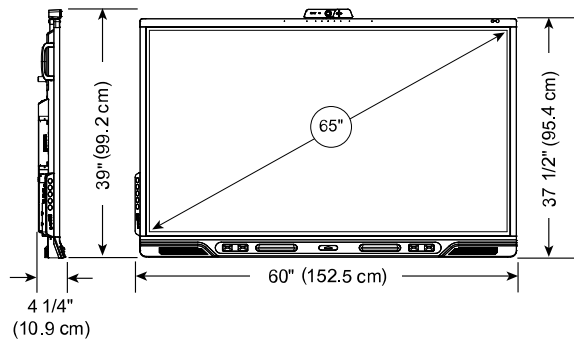

**Weight**

92.6 lb. (42 kg)

**Shipping dimensions (including pallet)**

65 1/2" × 46" × 7 1/8"  
(166.5 cm × 117 cm × 18 cm)

**Shipping weight**

108 lb. (49 kg)

**VESA mount**

M8 | 600 × 400 mm

**Handles**

2

**75" models**

**Dimensions**

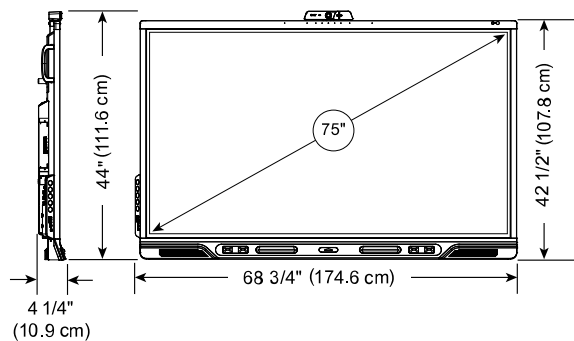

**Weight**

124 lb. (56 kg)

**Shipping dimensions (including pallet)**

74 5/8" × 50 7/8" × 7 1/8"  
(189.5 cm × 129.3 cm × 18 cm)

**Shipping weight**

147 lb. (67 kg)

**VESA mount**

M8 | 800 × 400 mm

**Handles**

2

**86" models**

**Dimensions**

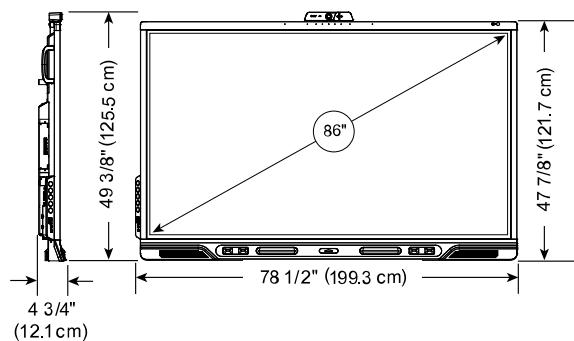

**Weight**

154 lb. (70 kg)

**Shipping dimensions (including pallet)**

84 1/4" × 57 1/4" × 7 5/8"  
(214 cm × 145.4 cm × 19.5 cm)

**Shipping weight**

190 lb. (86 kg)

**VESA mount**

M8 | 800 × 600 mm

**Handles**

2

---

**smarttech.com**  
**smarttech.com/contact**

© 2026 SMART Technologies ULC. All rights reserved. SMART Board, SMART Meeting Pro, SMART TeamWorks, SMART Ink, HyPr Touch, Tool Explorer, Simultaneous Tool Differentiation, Object Awareness, Pen ID, Silktouch, smarttech, the SMART logo and all SMART taglines are trademarks or registered trademarks of SMART Technologies ULC in the US and/or other countries. The Adopted Trademarks HDMI, HDMI High-Definition Multimedia Interface, and the HDMI Logo are trademarks or registered trademarks of HDMI Licensing Administrator, Inc. in the United States and other countries. The Bluetooth word mark is owned by the Bluetooth SIG, Inc. and any use of such marks by SMART Technologies ULC is under license. Android and Google Play are trademarks of Google Inc. All other third-party product and company names may be trademarks of their respective owners. This product and/or use thereof is covered by one or more of the following US patents: [www.smarttech.com/patents](http://www.smarttech.com/patents). Contents are subject to change without notice. January 14, 2026.